

# Dalmatic Insertable Dust Filters Series DLM V

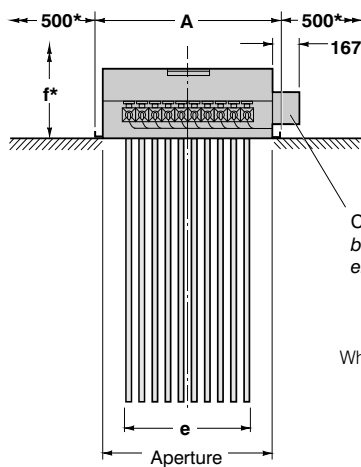

FRONT ELEVATION

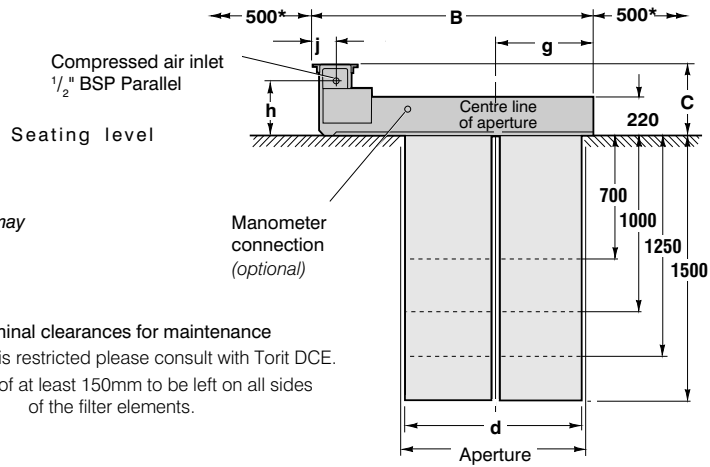

SIDE ELEVATION

\* Nominal clearances for maintenance  
Where space is restricted please consult with Torit DCE.  
Clearance of at least 150mm to be left on all sides  
of the filter elements.

## Dalmatic basic type insertable filter

Model DLM V30/15B illustrated, broken lines representing models DLM V14/7B, DLM V20/10B and DLM V25/12B  
Suitable for inside locations

DLM type	Fabric area	No. of elements	DIMENSIONS in millimetres										Approx. net weight
			A	B	C	d	e	f*	g	h	j		
V3/7B	3 m <sup>2</sup>	4	524	1015	375	480	294	850	310	295	115	80 kg**	
V4/7B	4 m <sup>2</sup>	6	700	1015	375	480	470	850	310	295	115	105 kg**	
V5/12B	5 m <sup>2</sup>	4	524	1015	375	480	294	1400	310	295	115	90 kg**	
V6/10B	6 m <sup>2</sup>	6	700	1015	375	480	470	1150	310	295	115	114 kg**	
V7/7B	7 m <sup>2</sup>	10	1100	1015	375	480	820	850	310	295	115	160 kg**	
V7.5/12B	7.5 m <sup>2</sup>	6	700	1015	375	480	470	1400	310	295	115	119 kg**	
V8/7B	8 m <sup>2</sup>	12	700	1625	400	1005	470	850	575	310	130	170 kg**	
V9/15B	9 m <sup>2</sup>	6	700	1015	375	480	470	1650	310	295	115	124 kg**	
V10/10B	10 m <sup>2</sup>	10	1100	1015	375	480	820	1150	310	295	115	175 kg**	
V12/10B	12 m <sup>2</sup>	12	700	1625	400	1005	470	1150	575	310	130	188 kg**	
V13/12B	13 m <sup>2</sup>	10	1100	1015	375	480	820	1400	310	295	115	184 kg**	
V14/7B	14 m <sup>2</sup>	20	1100	1625	400	1005	820	850	575	310	130	275 kg**	
V15/12B	15 m <sup>2</sup>	12	700	1625	400	1005	470	1400	575	310	130	198 kg**	
V15/15B	15 m <sup>2</sup>	10	1100	1015	375	480	820	1650	310	295	115	192 kg**	
V18/15B	18 m <sup>2</sup>	12	700	1625	400	1005	470	1650	575	310	130	208 kg**	
V20/10B	20 m <sup>2</sup>	20	1100	1625	400	1005	820	1150	575	310	130	305 kg**	
V21/7B	21 m <sup>2</sup>	30	1100	2225	400	1605	820	850	875	310	130	360 kg**	
V25/12B	25 m <sup>2</sup>	20	1100	1625	400	1005	820	1400	575	310	130	322 kg**	
V30/10B	30 m <sup>2</sup>	30	1100	2225	400	1605	820	1150	875	310	130	405 kg**	
V30/15B	30 m <sup>2</sup>	20	1100	1625	400	1005	820	1650	575	310	130	340 kg**	
V38/12B	38 m <sup>2</sup>	30	1100	2225	400	1605	820	1400	875	310	130	430 kg**	
V45/15B	45 m <sup>2</sup>	30	1100	2225	400	1605	820	1650	875	310	130	455 kg**	
V50/12B	50 m <sup>2</sup>	40	1100	2747	400	2130	820	1400	1137	310	130	564 kg**	
V60/15B	60 m <sup>2</sup>	40	1100	2747	400	2130	820	1650	1137	310	130	600 kg**	

\*\*Indicates heaviest configuration

## DALAMATIC INSERTABLE DUST FILTERS – SERIES DLM V

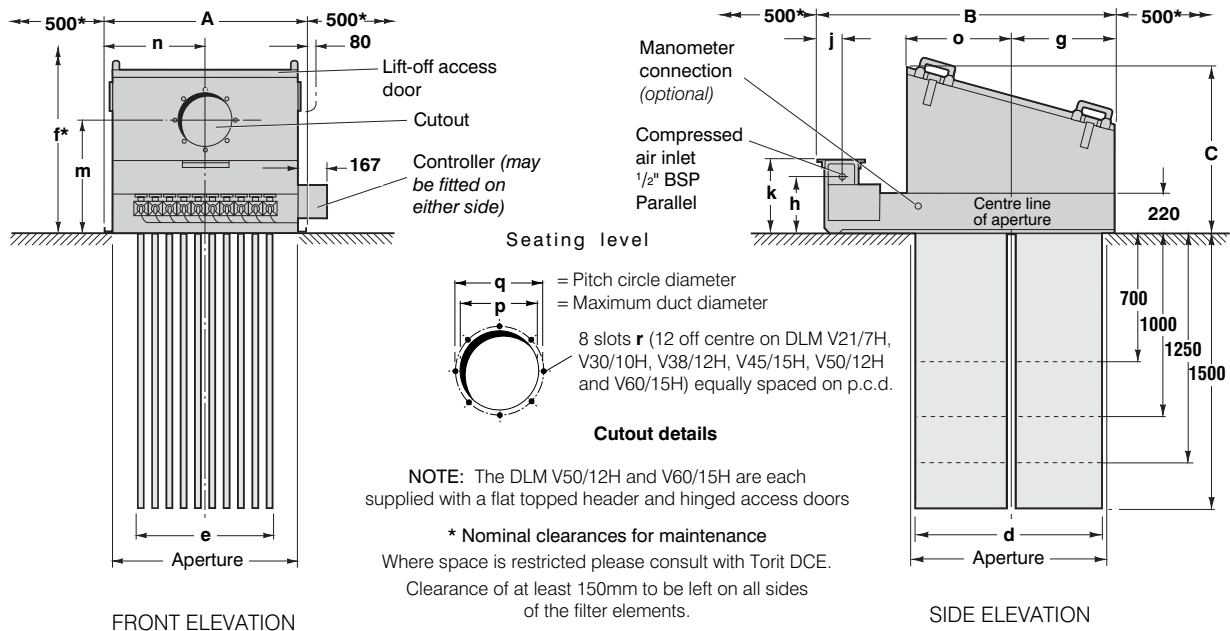

### Dalmatic insertable filter with exit header

Model DLM V30/15H illustrated, broken lines representing models DLM V14/7H, DLM V20/10H and DLM V25/12H  
Suitable for inside and outside locations

DLM type	Fabric area	No. of elements	DIMENSIONS in millimetres															Approx. net weight	
			A	B	C	d	e	f*	g	h	j	k	m	n	o	p	q		r
V3/7H	3 m <sup>2</sup>	4	524	1015	935	480	294	1250	310	295	115	375	552	227	295	220	245	8 x 12	115 kg**
V4/7H	4 m <sup>2</sup>	6	700	1015	935	480	470	1250	310	295	115	375	552	350	295	220	245	8 x 12	145 kg**
V5/12H	5 m <sup>2</sup>	4	524	1015	935	480	294	1800	310	295	115	375	552	227	295	220	245	8 x 12	145 kg**
V6/10H	6 m <sup>2</sup>	6	700	1015	935	480	470	1550	310	295	115	375	552	350	295	220	245	8 x 12	154 kg**
V7/7H	7 m <sup>2</sup>	10	1100	1015	935	480	820	1250	310	295	115	375	562	550	295	285	310	10 x 20	215 kg**
V7.5/12H	7.5 m <sup>2</sup>	6	700	1015	935	480	470	1800	310	295	115	375	552	350	295	220	245	8 x 12	159 kg**
V8/7H	8 m <sup>2</sup>	12	700	1625	935	1005	470	1250	575	310	130	400	592	290	555	285	310	10 x 20	235 kg**
V9/15H	9 m <sup>2</sup>	6	700	1015	935	480	470	2050	310	295	115	375	562	290	295	285	310	10 x 20	164 kg**
V10/10H	10 m <sup>2</sup>	10	1100	1015	935	480	820	1550	310	295	115	375	562	550	295	285	310	10 x 20	230 kg**
V12/10H	12 m <sup>2</sup>	12	700	1625	935	1005	470	1550	575	310	130	400	610	290	555	285	310	10 x 20	253 kg**
V13/12H	13 m <sup>2</sup>	10	1100	1015	935	480	820	1800	310	295	115	375	562	550	295	285	310	10 x 20	239 kg**
V14/7H	14 m <sup>2</sup>	20	1100	1625	935	1005	820	1250	575	310	130	400	610	550	555	285	310	10 x 20	360 kg**
V15/12H	15 m <sup>2</sup>	12	700	1625	935	1005	470	1800	575	310	130	400	610	290	555	285	310	10 x 20	263 kg**
V15/15H	15 m <sup>2</sup>	10	1100	1015	935	480	820	2050	310	295	115	375	580	550	295	285	310	10 x 20	247 kg**
V18/15H	18 m <sup>2</sup>	12	700	1625	935	1005	470	2050	575	310	130	400	610	290	555	285	310	10 x 20	273 kg**
V20/10H	20 m <sup>2</sup>	20	1100	1625	935	1005	820	1550	575	310	130	400	610	550	555	285	310	10 x 20	390 kg**
V21/7H	21 m <sup>2</sup>	30	1100	2225	1090	1605	820	1150	875	310	130	400	610	550	855	500	550	10 x 20	480 kg**
V25/12H	25 m <sup>2</sup>	20	1100	1625	935	1005	820	1800	575	310	130	400	610	550	555	285	310	10 x 20	407 kg**
V30/10H	30 m <sup>2</sup>	30	1100	2225	1090	1605	820	1450	875	310	130	400	630	550	855	500	550	10 x 20	525 kg**
V30/15H	30 m <sup>2</sup>	20	1100	1625	935	1005	820	2050	575	310	130	400	630	550	555	315	340	10 x 20	424 kg**
V38/12H	38 m <sup>2</sup>	30	1100	2225	1090	1605	820	1700	875	310	130	400	670	550	855	500	550	ø12	550 kg**
V45/15H	45 m <sup>2</sup>	30	1100	2225	1090	1605	820	1950	875	310	130	400	670	550	855	500	550	ø12	575 kg**
V50/12H	50 m <sup>2</sup>	40	1100	2747	1090	2130	820	1960	1137	310	130	400	670	550	1118	500	550	ø12	819 kg**
V60/15H	60 m <sup>2</sup>	40	1100	2747	1090	2130	820	2210	1137	310	130	400	670	550	1118	500	550	ø12	852 kg**

\*\*Indicates heaviest configuration

## DALAMATIC INSERTABLE DUST FILTERS – SERIES DLM V

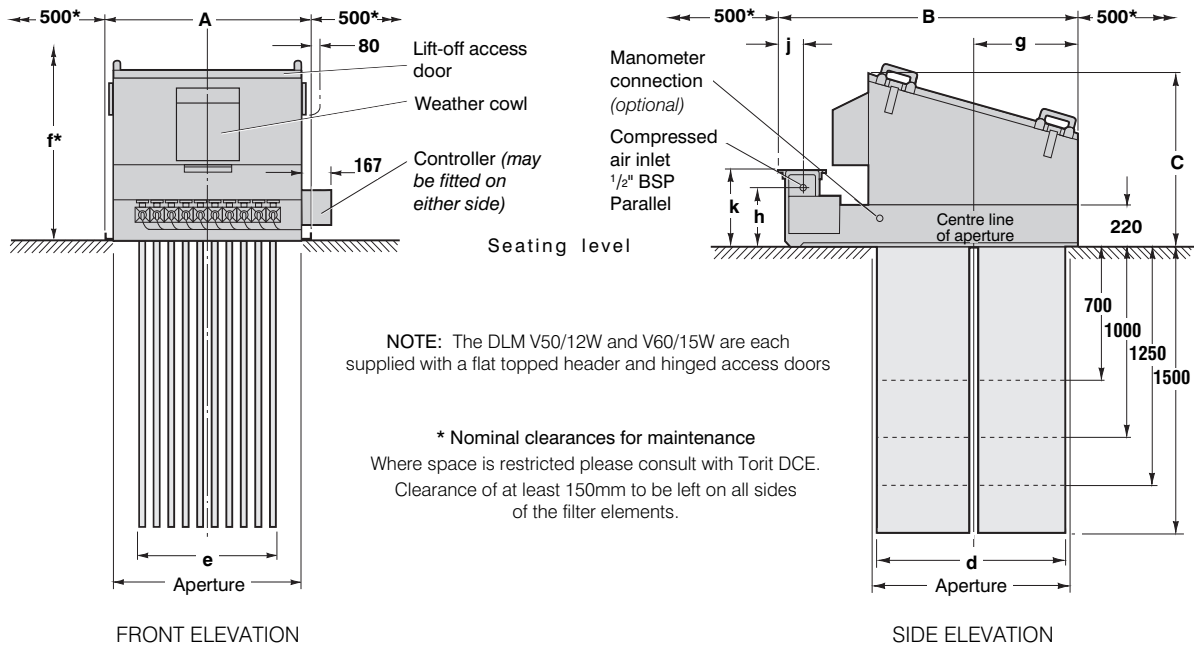

### Dalmatic insertable filter with weather cowl

Model DLM V30/15W illustrated, broken lines representing models DLM V14/7W, DLM V20/10W and DLM V25/12W  
Suitable for inside and outside locations

DLM type	Fabric area	No. of elements	DIMENSIONS in millimetres										Approx. net weight
			A	B	C	d	e	f*	g	h	j	k	
V3/7W	3 m <sup>2</sup>	4	524	1015	935	480	294	1250	310	295	115	375	118 kg**
V4/7W	4 m <sup>2</sup>	6	700	1015	935	480	470	1250	310	295	115	375	150 kg**
V5/12W	5 m <sup>2</sup>	4	524	1015	935	480	294	1800	310	295	115	375	128 kg**
V6/10W	6 m <sup>2</sup>	6	700	1015	935	480	470	1550	310	295	115	375	159 kg**
V7/7W	7 m <sup>2</sup>	10	1100	1015	935	480	820	1250	310	295	115	375	220 kg**
V7.5/12W	7.5 m <sup>2</sup>	6	700	1015	935	480	470	1800	310	295	115	375	164 kg**
V8/7W	8 m <sup>2</sup>	12	700	1625	935	1005	470	1250	575	310	130	400	240 kg**
V9/15W	9 m <sup>2</sup>	6	700	1015	935	480	470	2050	310	295	115	375	169 kg**
V10/10W	10 m <sup>2</sup>	10	1100	1015	935	480	820	1550	310	295	115	375	230 kg**
V12/10W	12 m <sup>2</sup>	12	700	1625	935	1005	470	1550	575	310	130	400	258 kg**
V13/12W	13 m <sup>2</sup>	10	1100	1015	935	480	820	1800	310	295	115	375	244 kg**
V14/7W	14 m <sup>2</sup>	20	1100	1625	935	1005	820	1250	575	310	130	400	365 kg**
V15/12W	15 m <sup>2</sup>	12	700	1625	935	1005	470	1800	575	310	130	400	268 kg**
V15/15W	15 m <sup>2</sup>	10	1100	1015	935	480	820	2050	310	295	115	375	252 kg**
V18/15W	18 m <sup>2</sup>	12	700	1625	935	1005	470	2050	575	310	130	400	278 kg**
V20/10W	20 m <sup>2</sup>	20	1100	1625	935	1005	820	1550	575	310	130	400	395 kg**
V21/7W	21 m <sup>2</sup>	30	1100	2225	1090	1605	820	1150	875	310	130	400	490 kg**
V25/12W	25 m <sup>2</sup>	20	1100	1625	935	1005	820	1800	575	310	130	400	412 kg**
V30/10W	30 m <sup>2</sup>	30	1100	2225	1090	1605	820	1450	875	310	130	400	535 kg**
V30/15W	30 m <sup>2</sup>	20	1100	1625	935	1005	820	2050	575	310	130	400	429 kg**
V38/12W	38 m <sup>2</sup>	30	1100	2225	1090	1605	820	1700	875	310	130	400	560 kg**
V45/15W	45 m <sup>2</sup>	30	1100	2225	1090	1605	820	1950	875	310	130	400	585 kg**
V50/12W	50 m <sup>2</sup>	40	1100	2747	1090	2130	820	1960	1137	310	130	400	829 kg**
V60/15W	60 m <sup>2</sup>	40	1100	2747	1090	2130	820	2210	1137	310	130	400	862 kg**

\*\*Indicates heaviest configuration

## DALAMATIC INSERTABLE DUST FILTERS – SERIES DLM V

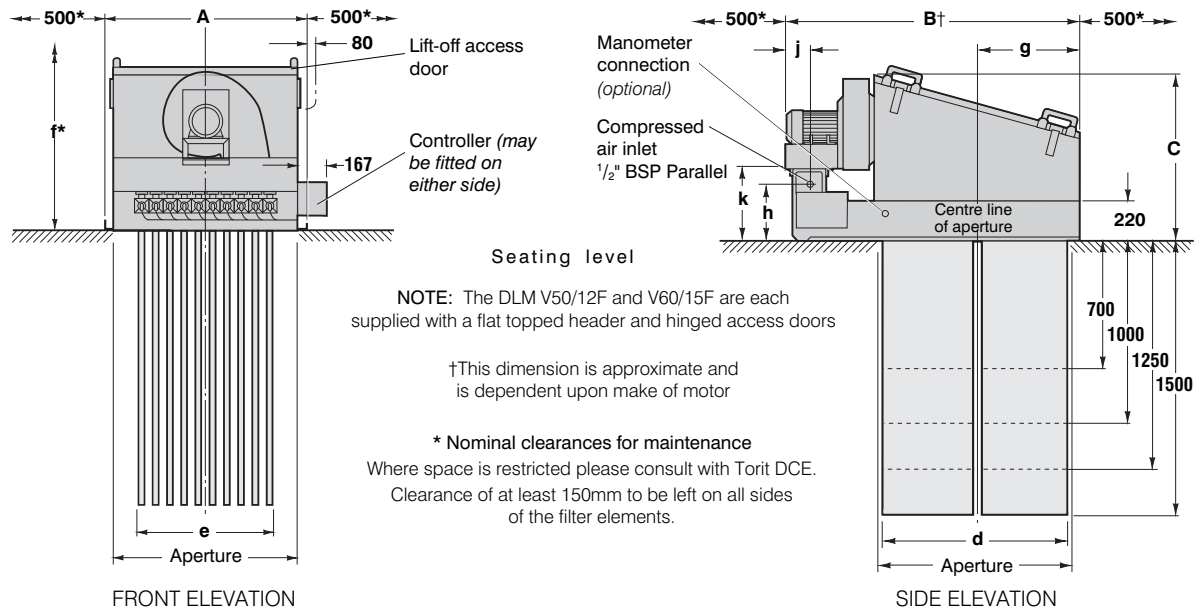

### Dalmatic insertable filter with integral fan

Model DLM V30/15F illustrated, broken lines representing models DLM V14/7F, DLM V20/10F and DLM V25/12F  
Suitable for inside and outside locations

DLM type	Fabric area	No. of elements	DIMENSIONS in millimetres										Fan	Fan motor	Approx. net weight
			A	B†	C	d	e	f*	g	h	j	k			
V3/7F	3 m <sup>2</sup>	4	524	1095	935	480	294	1250	310	295	195	375	F1	0.75 kW	165 kg**
V4/7F	4 m <sup>2</sup>	6	700	1095	935	480	470	1250	310	295	195	375	F1	0.75 kW	195 kg**
V5/12F	5 m <sup>2</sup>	4	524	1095	935	480	294	1800	310	295	195	375	F1	0.75 kW	175 kg**
V6/10F	6 m <sup>2</sup>	6	700	1095	935	480	470	1550	310	295	195	375	F1	0.75 kW	204 kg**
V7/7F	7 m <sup>2</sup>	10	1100	1095	935	480	820	1250	310	295	195	375	F1	0.75 kW	265 kg**
V7.5/12F	7.5 m <sup>2</sup>	6	700	1095	935	480	470	1800	310	295	195	375	K3	1.50 kW	270 kg**
V8/7F	8 m <sup>2</sup>	12	700	1625	935	1005	470	1250	575	310	130	400	F1	0.75 kW	209 kg**
V9/15F	9 m <sup>2</sup>	6	700	1095	935	480	470	2050	310	295	195	375	K3	1.50 kW	214 kg**
V10/10F	10 m <sup>2</sup>	10	1100	1095	935	480	820	1550	310	295	195	375	F1	0.75 kW	280 kg**
V12/10F	12 m <sup>2</sup>	12	700	1625	935	1005	470	1550	575	310	130	400	K3	1.50 kW	285 kg**
V13/12F	13 m <sup>2</sup>	10	1100	1095	935	480	820	1800	310	295	195	375	K5	2.20 kW	308 kg**
V14/7F	14 m <sup>2</sup>	20	1100	1625	935	1005	820	1250	575	310	130	400	K5	2.20 kW	323 kg**
V15/12F	15 m <sup>2</sup>	12	700	1625	935	1005	470	1800	575	310	130	400	K3	1.50 kW	294 kg**
V15/15F	15 m <sup>2</sup>	10	1100	1095	935	480	820	2050	310	295	195	375	K5	2.20 kW	309 kg**
V18/15F	18 m <sup>2</sup>	12	700	1625	935	1005	470	2050	575	310	130	400	K3	1.50 kW	415 kg**
V20/10F	20 m <sup>2</sup>	20	1100	1625	935	1005	820	1550	575	310	130	400	K5	2.20 kW	430 kg**
V21/7F	21 m <sup>2</sup>	30	1100	2225	1090	1605	820	1150	875	310	130	400	K7	3.00 kW	318 kg**
V25/12F	25 m <sup>2</sup>	20	1100	1625	935	1005	820	1800	575	310	180	400	K5	2.20 kW	333 kg**
V30/10F	30 m <sup>2</sup>	30	1100	2225	935	1605	820	1450	875	310	180	400	K3	1.50 kW	302 kg**
V30/15F	30 m <sup>2</sup>	20	1100	1625	935	1005	820	2050	575	310	180	400	K5	2.20 kW	317 kg**
V38/12F	38 m <sup>2</sup>	30	1100	2330	1090	1605	820	1700	875	310	235	400	K5	2.20 kW	328 kg**
V45/15F	45 m <sup>2</sup>	30	1100	2330	1090	1605	820	1950	875	310	235	400	K7	3.00 kW	343 kg**
V50/12F	50 m <sup>2</sup>	40	1100	2890	1090	2130	820	1960	1137	310	270	400	K7	3.00 kW	378 kg**
V60/15F	60 m <sup>2</sup>	40	1100	3130	1130	2130	820	2210	1137	310	270	400	K10	5.50 kW	445 kg**

\*\*Indicates heaviest configuration

## DALAMATIC INSERTABLE DUST FILTERS – SERIES DLM V

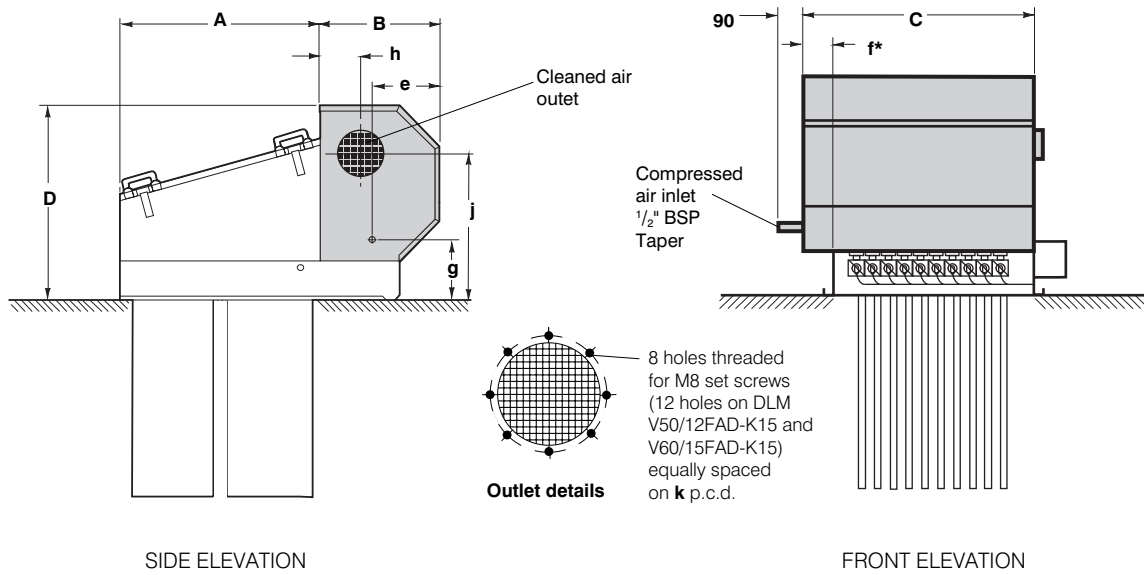

### Dalamic insertable acoustic diffuser details

Suitable for inside and outside locations.

Nominal clearances for maintenance are as shown on page 4.

\*Note: On models DLM V4/7FAD, V6/10FAD, V7.5/12FAD, V8/7FAD, V9/15FAD, V12/10FAD, V15/12FAD and V18/15FAD the acoustic diffuser overhangs on the left and the controller is on the right (as illustrated). On models DLM V50/12FAD-K15 and V60/15FAD-K15 the overhang is on the right and the controller is on the left. On all other models there is no overhang and the controller can be fitted on either side. In all cases the compressed air inlet pipe is on the opposite side to the controller.

DLM type	DIMENSIONS in millimetres										Approx. net weight
	A	B	C	D	e	f*	g	h	j	k	
V4/7FAD	605	600	740	1100	300	140	295	200	860	310	42 kg
V6/10FAD	605	600	740	1100	300	140	295	200	860	310	42 kg
V7/7FAD	605	600	1010	1100	300	–	295	200	860	310	47 kg
V7.5/12FAD	605	600	740	1100	300	140	295	200	860	310	42 kg
V8/7FAD	1130	690	740	1100	315	140	310	240	860	340	45 kg
V9/15FAD	605	600	740	1100	300	140	295	200	860	310	42 kg
V10/10FAD	605	600	1010	1100	300	–	295	200	860	310	47 kg
V12/10FAD	1130	690	740	1100	315	140	310	240	860	340	45 kg
V13/12FAD	605	600	1010	1100	300	–	295	200	860	310	47 kg
V14/7FAD	1130	690	1010	1100	315	–	310	240	860	340	50 kg
V15/12FAD	1130	690	740	1100	315	140	310	240	860	340	45 kg
V15/15FAD	605	600	1010	1100	300	–	295	200	860	310	47 kg
V18/15FAD	1130	690	740	1100	315	140	310	240	860	340	45 kg
V20/10FAD	1130	690	1010	1100	315	–	310	240	860	340	50 kg
V21/7FAD	1730	810	1010	1190	440	–	310	265	910	390	58 kg
V25/12FAD	1130	690	1010	1100	315	–	310	240	860	340	50 kg
V30/10FAD	1730	810	1010	1190	440	–	310	265	910	390	58 kg
V30/15FAD	1130	690	1010	1100	315	–	310	240	860	340	50 kg
V38/12FAD	1730	810	1010	1190	440	–	310	265	910	390	58 kg
V45/15FAD	1730	810	1010	1190	440	–	310	265	910	390	58 kg
V50/12FAD-K11	2255	810	1010	1190	440	–	310	265	910	390	60 kg
V50/12FAD-K15	2255	960	1215	1250	445	215	310	330	895	520	85 kg
V60/15FAD-K11	2255	810	1010	1190	440	–	310	265	910	390	60 kg
V60/15FAD-K15	2255	960	1215	1250	445	215	310	330	895	520	85 kg

## DALAMATIC INSERTABLE DUST FILTERS – SERIES DLM V

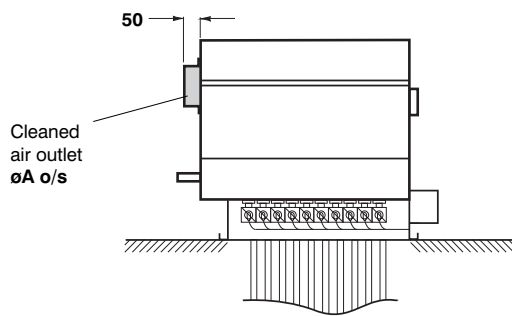

FRONT ELEVATION

### Optional acoustic diffuser duct connection spigot

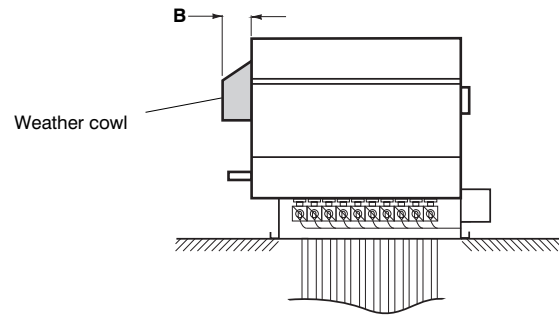

FRONT ELEVATION

### Optional acoustic diffuser weather cowl

#### DLM Type

V4/7FAD, V6/10FAD, V7/7FAD, V7.5/12FAD,  
V9/15FAD, V10/10FAD, V13/12FAD and V15/15FAD

V8/7FAD, V12/10FAD, V14/7FAD, V15/12FAD,  
V18/15FAD, V20/10FAD, V25/12FAD and V30/15FAD

V21/7FAD, V30/10FAD, V38/12FAD, V45/15FAD,  
V50/12FAD and V60/15FAD

V50/12FAD-K15 and V60/15FAD-K15

#### Dimensions in millimetres

A                      B

270                      172

300                      196

350                      240

480                      260

### ELECTRICAL REQUIREMENTS

**Filters up to DLM V20/10\*:** 2-, 3- or 5-way controller

**Filters from DLM V20/10\* upwards:** 10-way controller

**Voltage input:** AC version: 105-120V, 200-240V. (± 10%) DC version: 24V D.C.

**Fan motor (if fitted):** To suit local voltage

\*The DLM V20/10 can be supplied with either 5- or 10-way controller

### DESIGN LIMITS (standard equipment)

**Temperature range** (alternatives according to type of sealer used): (1) -10° to +60°C; (2) -10° to +200°C (not type F)

**Pressure limits:** (a) Types B, W & H: -400mm W.G. For positive pressures please refer to Torit DCE;

(b) Type S: -5500mm W.G. For positive pressures please refer to Torit DCE;

(c) Type F: as fan performance curves from shut-off to ambient pressure

**Dimension tolerances:** ± 5mm on main dimensions; ± 2mm on detail dimensions

# DALAMATIC INSERTABLE DUST FILTERS – SERIES DLM V

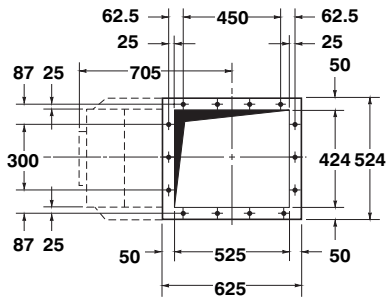

**DLM V3/7 and V5/12**

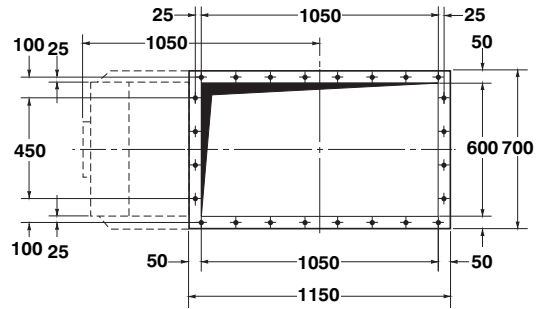

**DLM V8/7, V12/10, V15/12 and V18/15**

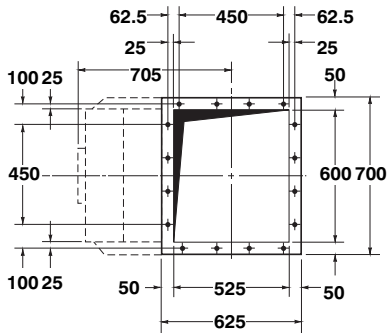

**DLM V4/7, V6/10, V7.5/12 and V9/15**

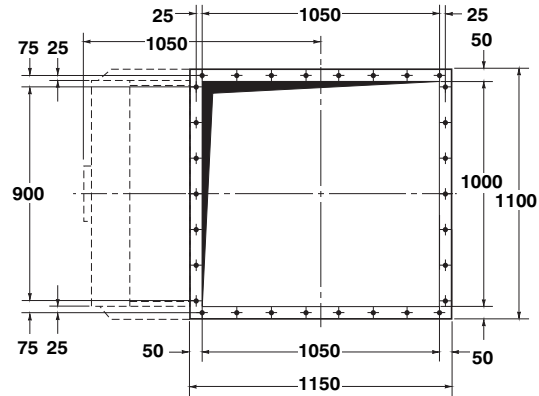

**DLM V14/7, V20/10, V25/12 and V30/15**

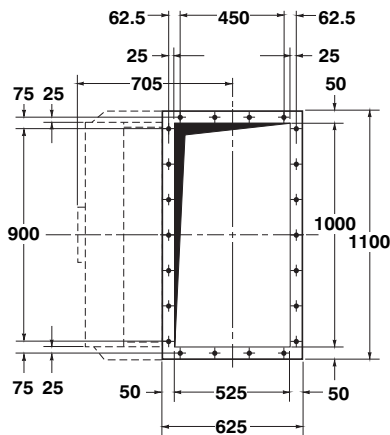

**DLM V7/7, V10/10, V13/12 and V15/15**

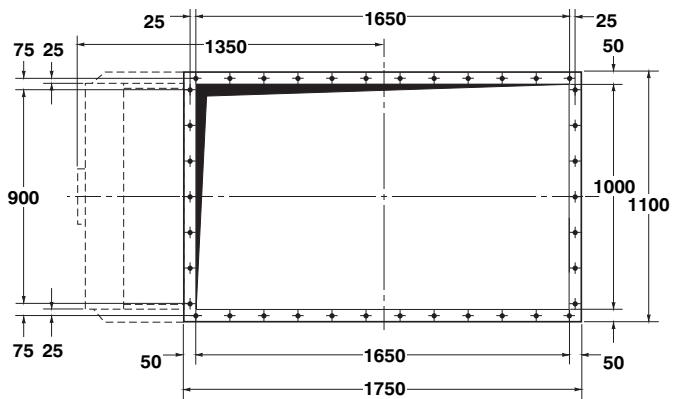

**DLM V21/7, V30/10, V38/12 and V45/15**

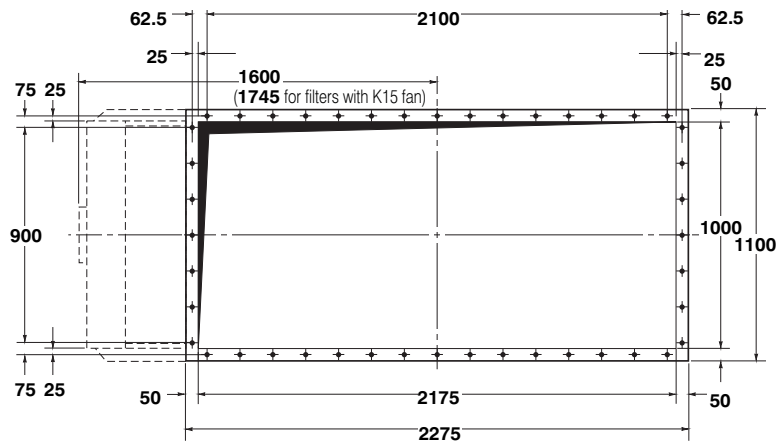

**DLM V50/12 and V60/15**

**Aperture and mounting flange details for types B, W, H and F filters**

All bolt holes  $\varnothing 12\text{mm}$  for M10 set screws. Pitch centres: 150mm

## DALAMATIC INSERTABLE DUST FILTERS – SERIES DLM V

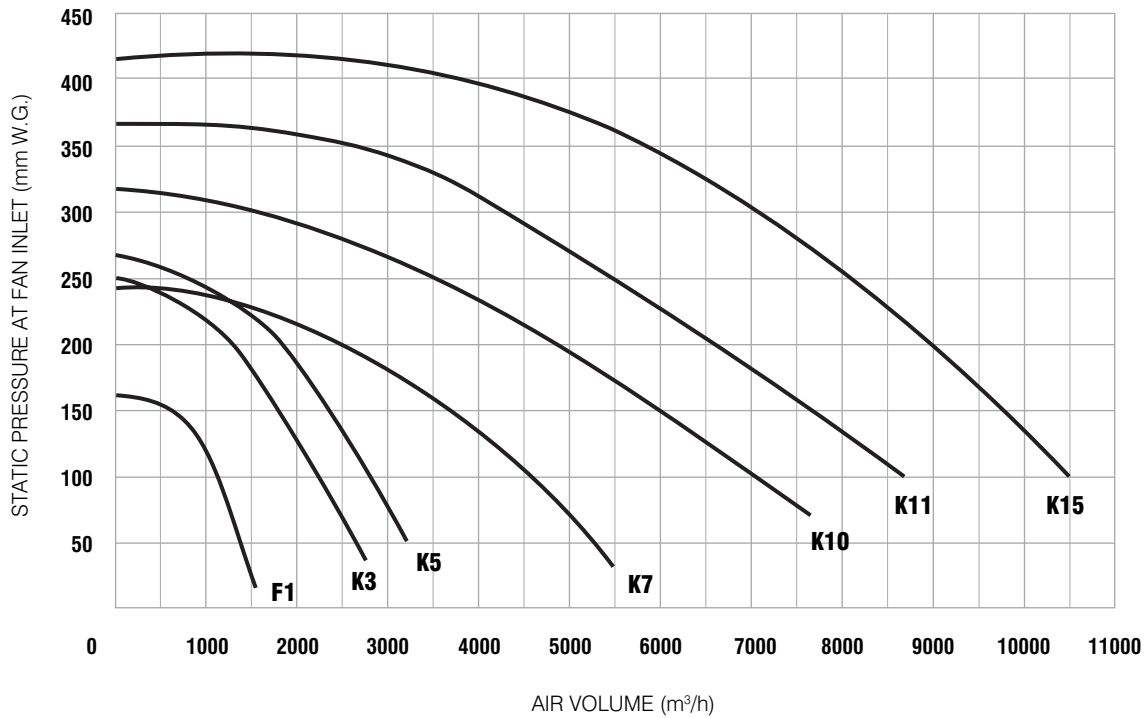

**Fan performance curves**

### FAN SELECTION

To select the most suitable fan for a given application:

- 1 Determine the air volume flow (m³/h) needed to give effective venting and dust control.
- 2 Estimate pressure or suction (mm W.G.) in the housing in which the dust filter is inserted.
- 3 Assess the operational pressure drop (mmW.G.) across the clean side and dirty side of the filtering element – usually between 25 to 100mm W.G.
- 4 The sum of 2 and 3 gives the pressure (mmW.G.) required for fan selection purposes.
- 5 Consult graph for fan performances available.

### NOISE LEVELS

Machinery noise levels are an important consideration in the design and selection of new equipment. Several EC Directives and National Laws/Regulations adopting these directives make reference to airborne noise emissions. Actions that employers are required to comply with if employees are subjected to a daily personal noise exposure level of 85 dB(A) or more are also specified.

All Dalamatic insertable filters, when fitted with acoustic diffuser, are below this action limit.

### WEIGHTED SOUND PRESSURE LEVELS

All readings were taken in normal industrial areas, i.e. semi-reverberant surroundings, with local equipment silent. Measurements were taken at maximum air flow conditions at 1.0 metre radius from the equipment housing and 1.6 metres above base level, using a precision sound level meter and octave filter.

	<b>F1 (0.75 kW)</b>	<b>K3 (1.5 kW)</b>	<b>K5 (2.2 kW)</b>	<b>K7 (3.0 kW)</b>	<b>K10 (5.5 kW)</b>	<b>K11 (7.5 kW)</b>	<b>K15 (11kW)</b>
With acoustic	76 dB(A)	73 dB(A)	74 dB(A)	76 dB(A)	79 dB(A)*	84 dB(A)	85 dB(A)
Without acoustic	91 dB(A)	89 dB(A)	92 dB(A)	93 dB(A)	94 dB(A)	97 dB(A)	99 dB(A)

Noise measurements of installed equipment may vary due to site conditions.

\* Estimated data



## DALAMATIC INSERTABLE DUST FILTERS – SERIES DLM V

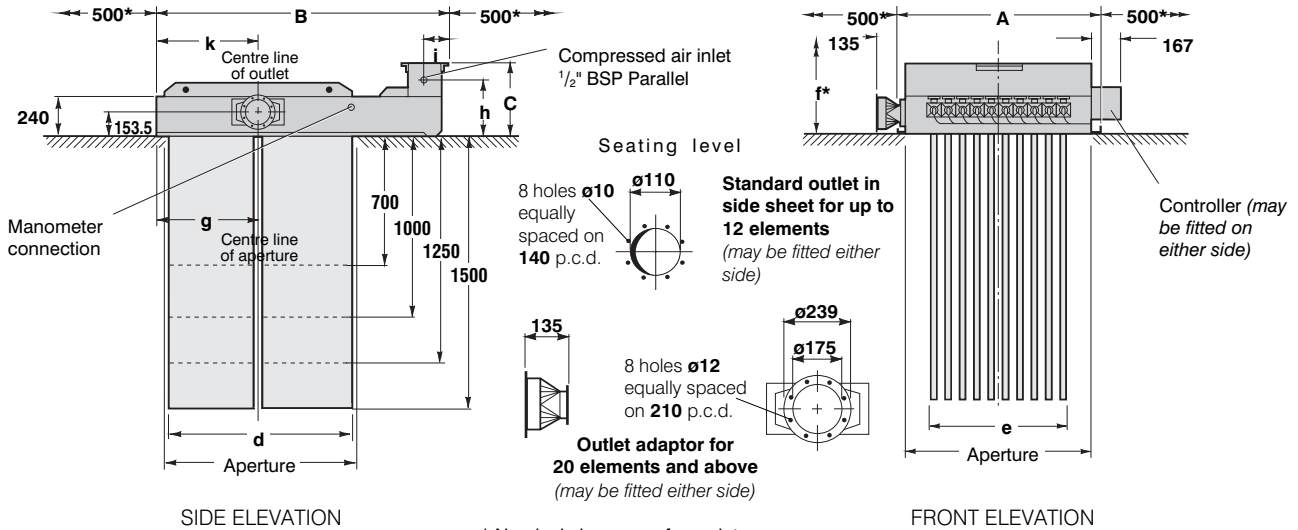

\* Nominal clearances for maintenance  
Where space is restricted please consult with Torit DCE.  
Clearance of at least 150mm to be left on all sides  
of the filter elements.

### Dalmatic S type insertable filter

Model DLM V30/15S illustrated, broken lines representing models DLM V14/7S, DLM V20/10S and DLM V25/12S  
Suitable for inside and outside locations

DLM type	Fabric area	No. of elements	DIMENSIONS in millimetres										Approx. net weight
			A	B	C	d	e	f*	g	h	j	k	
V3/7S	3 m <sup>2</sup>	4	524	1015	395	480	294	850	310	315	115	310	110 kg
V4/7S	4 m <sup>2</sup>	6	700	1015	395	480	470	850	310	315	115	310	140 kg
V5/12S	5 m <sup>2</sup>	4	524	1015	395	480	294	1400	310	315	115	310	116 kg
V6/10S	6 m <sup>2</sup>	6	700	1015	395	480	470	1150	310	315	115	310	150 kg
V7/7S	7 m <sup>2</sup>	10	1100	1015	395	480	820	850	310	315	115	310	205 kg
V7.5/12S	7.5 m <sup>2</sup>	6	700	1015	395	480	470	1400	310	315	115	310	155 kg
V8/7S	8 m <sup>2</sup>	12	700	1625	420	1005	470	850	575	330	130	565	220 kg
V9/15S	9 m <sup>2</sup>	6	700	1015	395	480	470	1650	310	315	115	310	160 kg
V10/10S	10 m <sup>2</sup>	10	1100	1015	395	480	820	1150	310	315	115	310	225 kg
V12/10S	12 m <sup>2</sup>	12	700	1625	420	1005	470	1150	575	330	130	565	240 kg
V13/12S	13 m <sup>2</sup>	10	1100	1015	395	480	820	1400	310	315	115	310	233 kg
V14/7S	14 m <sup>2</sup>	20	1100	1625	420	1005	820	850	575	330	130	592	370 kg
V15/12S	15 m <sup>2</sup>	12	700	1625	420	1005	470	1400	575	330	130	565	249 kg
V15/15S	15 m <sup>2</sup>	10	1100	1015	395	480	820	1650	310	315	115	310	245 kg
V18/15S	18 m <sup>2</sup>	12	700	1625	420	1005	470	1650	575	330	130	565	265kg
V20/10S	20 m <sup>2</sup>	20	1100	1625	420	1005	820	1150	575	330	130	592	405 kg
V21/7S	21 m <sup>2</sup>	30	1100	2225	420	1605	820	850	875	330	130	742	525 kg
V25/12S	25 m <sup>2</sup>	20	1100	1625	420	1005	820	1400	575	330	130	592	420 kg
V30/10S	30 m <sup>2</sup>	30	1100	2225	420	1605	820	1150	875	330	130	742	570 kg
V30/15S	30 m <sup>2</sup>	20	1100	1625	420	1005	820	1650	575	330	130	592	455 kg
V38/12S	38 m <sup>2</sup>	30	1100	2225	420	1605	820	1400	875	330	130	742	592 kg
V45/15S	45 m <sup>2</sup>	30	1100	2225	420	1605	820	1650	875	330	130	742	630 kg
V50/12S	50 m <sup>2</sup>	40	1100	2747	420	2130	820	1400	1137	330	130	1234	790 kg
V60/15S	60 m <sup>2</sup>	40	1100	2747	420	2130	820	1650	1137	330	130	1234	820 kg

## DALAMATIC INSERTABLE DUST FILTERS – SERIES DLM V

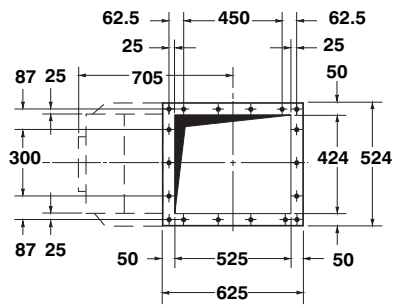

**DLM V3/7 and V5/12**

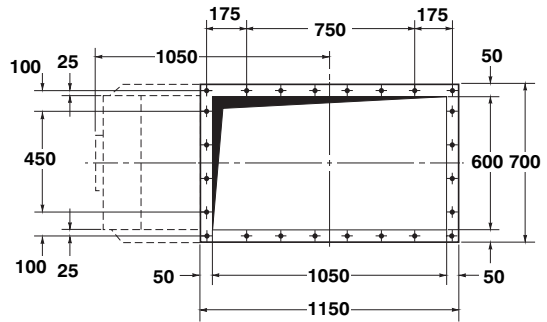

**DLM V8/7, V12/10, V15/12 and V18/15**

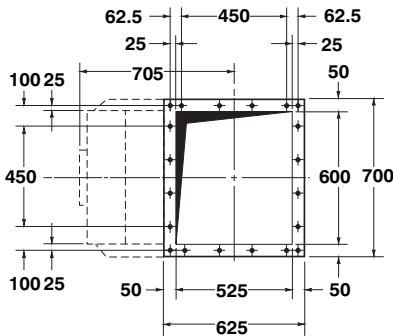

**DLM V4/7, V6/10, V7.5/12 and V9/15**

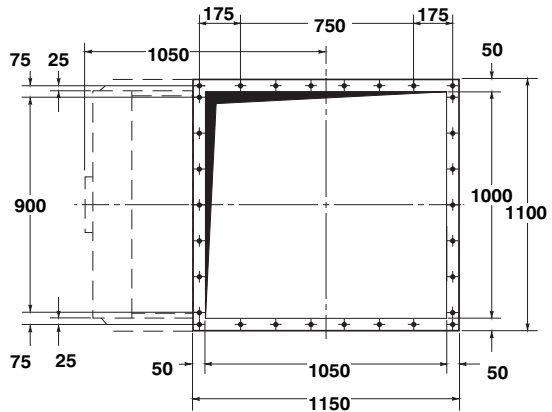

**DLM V14/7, V20/10, V25/12 and V30/15**

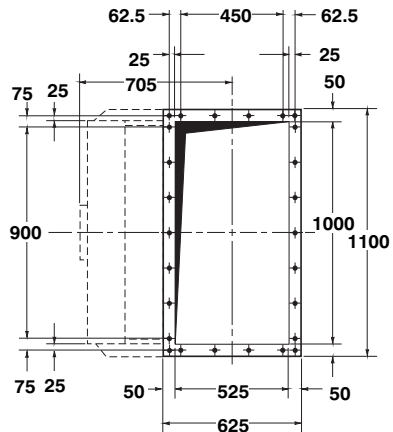

**DLM V7/7, V10/10, V13/12 and V15/15**

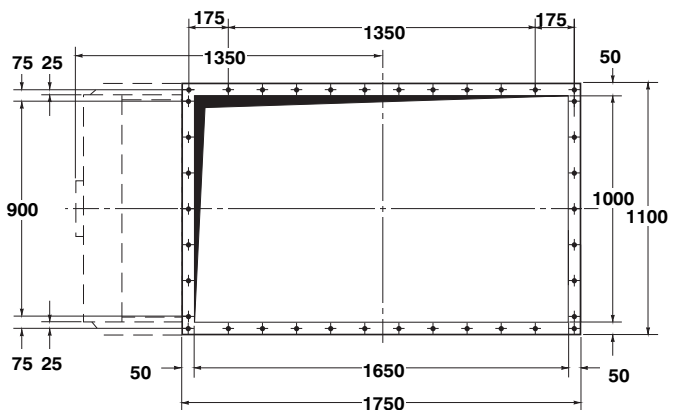

**DLM V21/7, V30/10, V38/12 and V45/15**

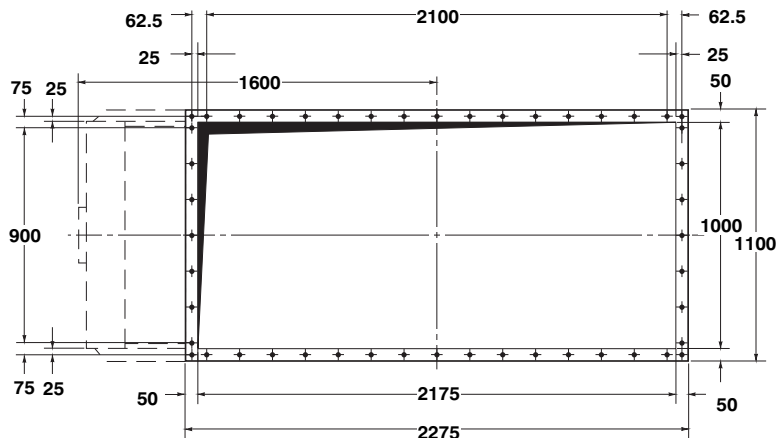

**DLM V50/12 and V60/15**

**Aperture and mounting flange details for type S filter**

All bolt holes  $\varnothing 12\text{mm}$  for M10 set screws. Pitch centres: 150mm

## DALAMATIC INSERTABLE DUST FILTERS – SERIES DLM V

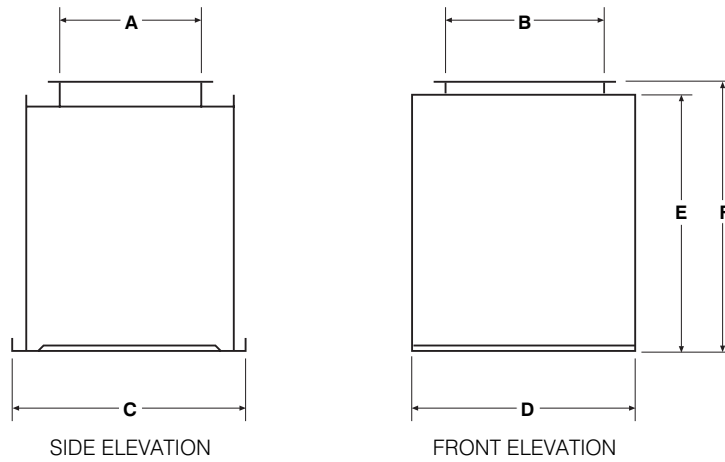

**Vertical upstand housing assembly**

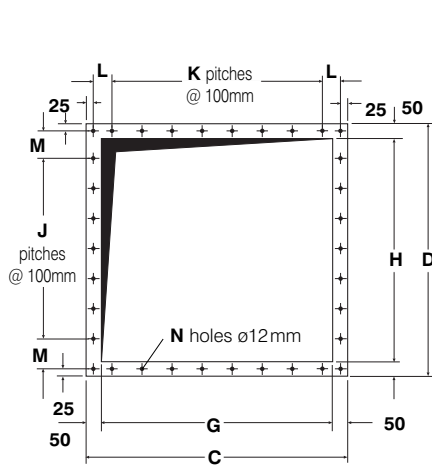

**Vertical upstand  
base flange details for all filters  
except DLM V30/10 and V21/7**

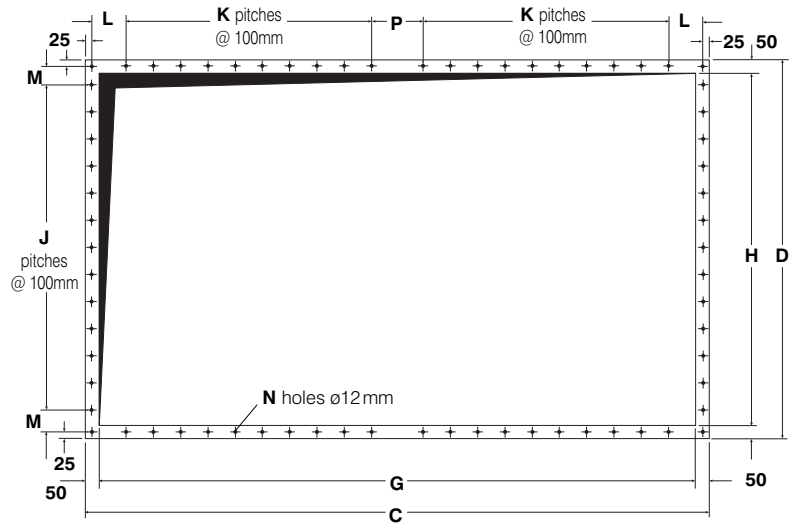

**Vertical upstand base flange details  
for DLM V30/10 and V21/7**

DLM type	DIMENSIONS in millimetres													
	A	B	C	D	E	F	G	H	J	K	L	M	N	P
V4/7 & V6/10	525	600	875	840	950	1000	775	740	6	7	62.5	95	34	-
V7/7 & V10/10	525	1000	875	1200	950	1000	775	1100	10	7	62.5	75	42	-
V7.5/12 & V9/15	525	600	1000	1050	1450	1500	900	950	10	8	75	-	40	-
V8/7 & V1210	1050	600	1500	840	950	1000	1400	740	6	13	75	95	46	-
V13/12 & V15/15	525	1000	1200	1200	1450	1500	1100	1100	10	9	125	75	46	-
V14/7 & V20/10	1050	1000	1500	1400	950	1000	1400	1300	12	13	75	75	58	-
V15/12 & V18/15	1050	600	1500	1050	1450	1500	1400	950	10	13	75	-	50	-
V21/7 & V30/10	1650	1000	2300	1400	950	1000	2200	1300	12	9	125	75	70	200
V25/12 & V30/15	1050	1000	1900	1400	1450	1500	1800	1300	12	17	75	75	66	-
V38/12 & V45/15	1650	1000	2800	1400	1450	1500	2700	1300	12	26	75	75	84	-
V50/12 & V60/15	2175	1000	3700	1400	1450	1500	3600	1300	12	35	75	75	102	-

## COMPRESSED AIR REQUIREMENTS

Filter type	Working compressed air pressure <sup>a</sup>		Atmospheric air volume – F.A.D. <sup>b</sup>		Pulse duration
	bar	psig	at 25 sec. intervals <sup>c</sup>		
<b>DLM V3/7 and V5/12</b>	4.5	65	3.1 m <sup>3</sup> /h	1.8 cfm	200 millisec.
<b>DLM V4/7, V6/10, V7.5/12 and V9/15</b>	4.5	65	3.9 m <sup>3</sup> /h	2.3 cfm	200 millisec.
<b>DLM V7/7, V10/10, V13/12 and V15/15</b>	4.5	65	4.7 m <sup>3</sup> /h	2.8 cfm	200 millisec.
<b>DLM V8/7, V12/10, V15/12 and V18/15</b>	6.2	90	7.1 m <sup>3</sup> /h	4.2 cfm	200 millisec.
<b>DLM V14/7 and V20/10 (5 valve)</b>	6.2	90	8.5 m <sup>3</sup> /h	5.0 cfm	200 millisec.
			at 12 sec. intervals <sup>c</sup>		
<b>DLM V20/10 (10 valve)</b>	4.5	65	6.1 m <sup>3</sup> /h	3.6 cfm	60 millisec.
<b>DLM V21/7 and V30/10</b>	5.2	75	7.8 m <sup>3</sup> /h	4.6 cfm	60 millisec.
<b>DLM V25/12 and V30/15</b>	4.5	65	8.7 m <sup>3</sup> /h	5.1 cfm	110 millisec.
<b>DLM V38/12 and V45/15</b>	5.2	75	11.2 m <sup>3</sup> /h	6.6 cfm	110 millisec.
<b>DLM V50/12 and V60/15</b>	6.2	90	16.1 m <sup>3</sup> /h	9.5 cfm	110 millisec.

<sup>a</sup> Normal operating pressure.    <sup>b</sup> Recommended atmospheric air volume of clean, dry compressed air.

<sup>c</sup> Recommended initial settings; these may be varied with experience.

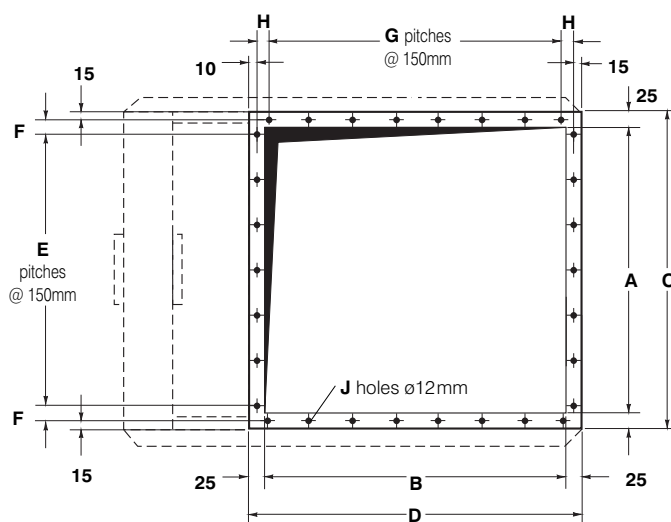

**Exit header mounting flange details**

DLM type	DIMENSIONS in millimetres								
	A	B	C	D	E	F	G	H	J
<b>V3/7B &amp; V5/12B</b>	378	550	428	600	2	49	3	62.5	14
<b>V4/7B, V6/10B, V7.5/12B &amp; V9/15B</b>	554	550	604	600	3	62	3	62.5	16
<b>V7.7B, V10/10B, V13/12B &amp; V15/15B</b>	954	550	1004	600	6	37	3	62.5	22
<b>V8/7B, V12/10B, V15/12B &amp; V18/15B</b>	554	1075	604	1125	3	62	7	25	24
<b>V14/7B, V20/10B, V25/12B &amp; V30/15B</b>	954	1075	1004	1125	6	37	7	25	30
<b>V21/7B, V30/10B, V38/12B &amp; V45/15B</b>	954	1675	1004	1725	6	37	11	25	38
<b>V50/12B &amp; V60/15B</b>	954	2200	1004	2250	6	37	14	62.5	44



Donaldson Dust Collection Group

**Torit DCE**, Humberstone Lane, Thurmaston, Leicester LE4 8HP, England  
 Tel +44 (0)116 269 6161 Fax +44 (0)116 269 3028  
 Email: toritdce.uk@mail.donaldson.com

**European Head Office**

**Torit DCE**, Interleuvenlaan, B-3001 Leuven (Heverlee), Belgium.  
 Tel +32 (0)16 383 970 Fax +32 (0)16 383 938 Email: toritdce.be@mail.donaldson.com

<http://www.toritdce.com>